

Operating instructions
Pneumatic Crimper AC 100-T

CE

Keep for future use!

Basic information

The basic prerequisite for ensuring safe use and continuous operation of the AC 100-T is knowledge of and compliance with the safety instructions.

It is a question of your own safety!

All persons working with the AC 100-T must observe the notes on safety.

In addition, rules and regulations that apply to the place of use, particularly regarding accident prevention, must be observed.

Symbols

The following symbols will be used in these operating instructions:



Indicates a possible **accident or injury hazard** and/or possible **damage** to the AC 100-T.



Indicates **notes on application**.

Dangerousness of the machine

The AC 100-T has been constructed according to recognised technical safety regulations and has undergone a safety examination and received official acceptance.

It is equipped with safety devices.

However, operating error and misuse could present a danger to

- life and limb of the operator,
- the machine.

The AC 100-T should only be used

- for the designated application and
- in perfect condition with regard to technical safety.

All persons involved with commissioning, operating and maintaining the AC 100-T, must

- be appropriately qualified and
 - follow these operating instructions precisely.
-

Designated use

The AC 100-T is to be used exclusively for crimping wire-end ferrules with cross sections between 4 and 10 mm². Under no circumstances should large metal parts or similar objects be introduced, the die set will be ruined.

Unauthorised amendments to the AC 100-T are prohibited for safety reasons!

! Observation of all instructions and compliance with the prescribed operating conditions are part of the designated use.

Sources of danger

The AC 100-T must only be operated when the finger guard plate is screwed on.

Only filtered compressed air with a maximum pressure of 6 bar can be used.

Disconnect the machine from the compressed air before working on the AC 100-T, during breaks and when the device is not in use. Do **not** pull on the compressed air tubing to disconnect.

Work places

The following should be avoided for operation and storage:

- damp or dusty places,
- places which are subject to high levels of heat, direct sunlight or low temperatures (operating range: 15 °C to 35 °C).

Protect the compressed air tubing from heat, oil and sharp edges.

Safety devices

The AC 100-T has a finger guard plate at the front as a contact safety device.

Under no circumstances should this be removed.

The AC 100-T is stopped when disconnected from the compressed air supply.

Permitted operators

Only authorised and instructed operators can work on the AC 100-T.

The operator is responsible to third parties in the working area.

The owner must

- make the operating instructions available to the operator and
- make sure that the operator has read and understood them.

Guarantee

In principle, our "General terms of purchase and delivery" apply. These are available to the owner when the contract is concluded at the latest.

Guarantee and liability claims resulting from damage to personnel or property are inadmissible if the following points have been violated:

- Non-designated use of the AC 100-T.
- Inappropriate working places.
- Inappropriate use and use which goes beyond that described in the operating instructions.
- Unauthorised structural amendments to the AC 100-T.
- Continued use of the AC 100-T when a malfunction has been established.
- Repairs carried out inappropriately.

! Only use original spare parts.

Application

The AC 100-T is a pneumatic crimping tool for wire-end ferrules with a cross-section of between 4 and 10 mm².

The AC 100-T comprises a tabletop unit and a foot-operated switch. As both hands are free to insert the wire with fitted wire-end ferrules, the AC 100-T is ideally suited to pre-confectioning cables.

Components

- 1 Tabletop unit
- 2 Compressed-air tubing
- 3 Foot-operated switch
- 4 Switch
- 5 Storage compartment for wire-end ferrules
- 6 Head
- 7 Finger guard plate
- 8 Die set

Accessories

- 9 Table clamp

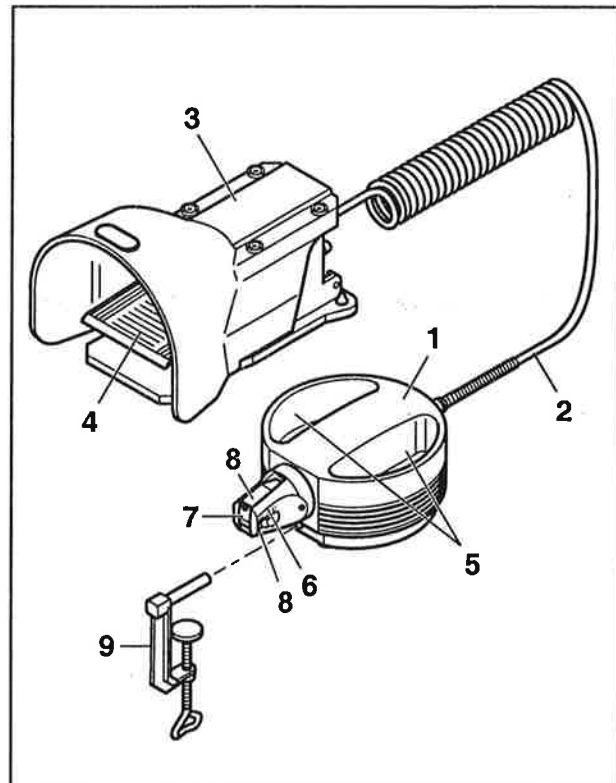

Fig. 1 Spare parts

Commissioning

- Check whether finger guard plate (1) is present and is sitting firm.
- Check whether the die set (2) is free from foreign matter.
- Check whether the pneumatic tubing nuts (3) have been tightened firmly.
- Introduce the table clamp into the bore hole in the tabletop unit and screw tightly to the worktable.
- Check the compressed-air supply:



min. 4 bar, max. 6 bar filtered air.

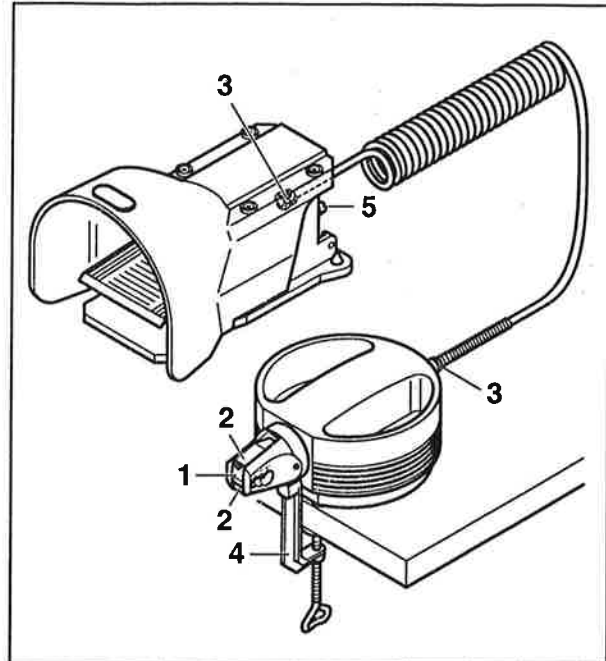

Fig. 2 Commissioning

- Connect the free connection (5) on the foot switch to the compressed-air supply.

Operation

- Introduce stripped wire, with wire-end ferrules already fitted, at the side (1) in the hole assigned to the cross-section.
- Press the switch (2), the crimping process will be triggered.
- Release the switch (3), the crimped wire can be removed again (4).

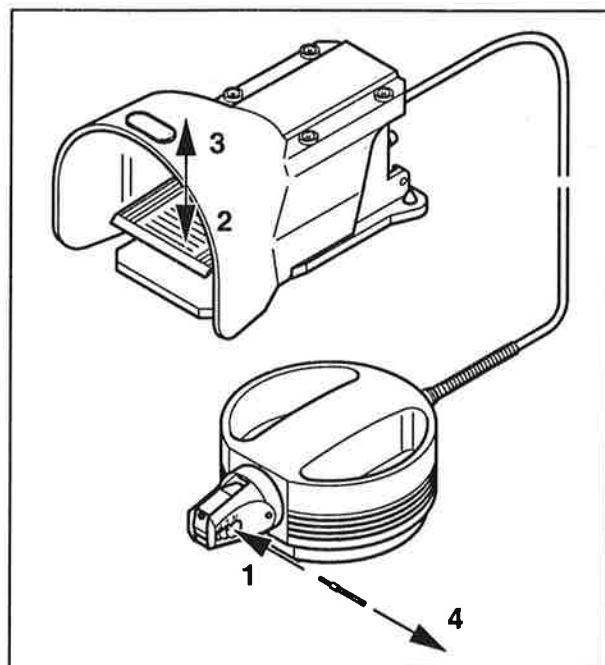

Fig. 3 Operation



The AC 100-T must be opened.
Disconnect compressed air!

Cleaning

- Unscrew hexagon socket screw (1).
- Pull out the die set (2).
- Clean die set (3) and lightly oil pivot (4).
- Push in die set (5).
- Tighten hexagon socket screw (6).

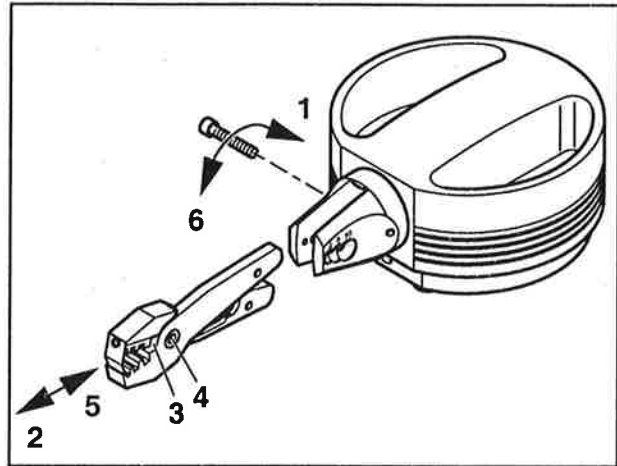

Fig. 4 Cleaning

Lubrication

- Unscrew the head (1).
- Remove the spring (2) and piston (3).
- Lubricate the two arms of the die set (4) (e. g. Gleitmo 746).
- Insert piston and spring.
- Insert head (5) and fasten fingertight.
- Pay attention that the arms of the die set (4) are correctly engaged in the piston (3).

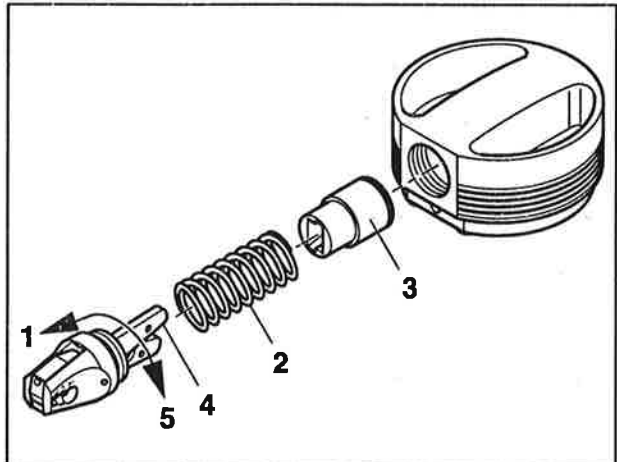

Fig. 5 Lubrication

The following spare parts can be ordered with the appropriate Article No.

Address

GLW Elektrotechnische Bauteile
 Kunststoffverarbeitung GmbH
 Steinbeisstraße 2
 D-88353 Kisslegg
 Tel. 00 49 (0) 7563 9123-0
 Fax 00 49 (0) 7563 9123-99

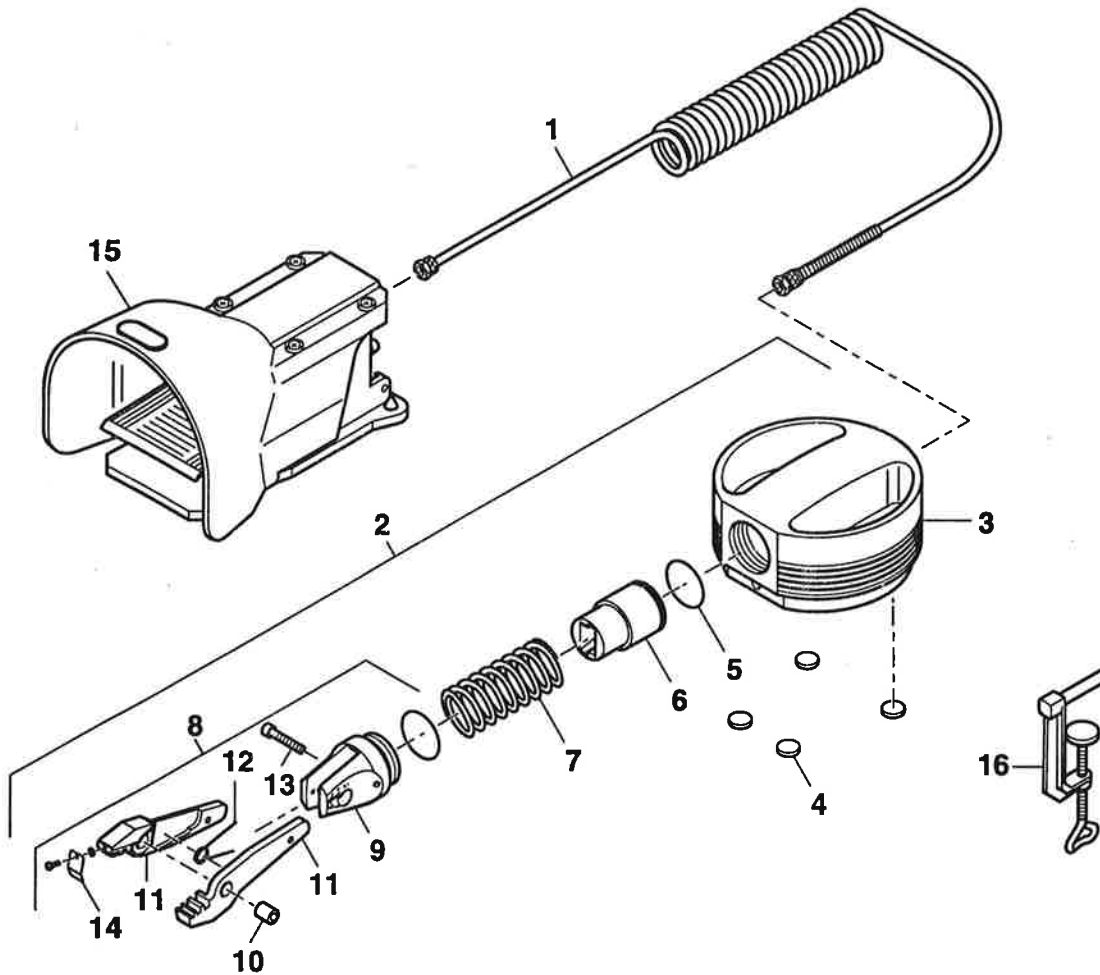

Fig.6 Spare parts

| No. | Part | Article No. | No. | Part | Article No. |
|-----|-------------------------|-------------|-----|----------------------|-------------|
| 1 | Compressed-air tubing | 2534 | 9 | Head section | 10005 |
| 2 | Tabletop unit, complete | 10060 | 10 | Pivot pin | 2503 |
| 3 | Body | 2531 | 11 | Die set | 10001 |
| 4 | Adhesive rubber pads | 2537 | 12 | Finger spring | 2502 |
| 5 | Sealing ring | 2520 | 13 | Hexagon socket screw | 2504 |
| 6 | Piston | 2507 | 14 | Finger guard plate | 10000 |
| 7 | Spring | 2506 | 15 | Foot-operated switch | 2536 |
| 8 | Head, complete | 10040 | 16 | Table clamp | 2538 |

Instrument.....Pneumatic Crimper
Crimping range 4 -10 mm²
Compressed-air connection min. 4 bar
..... max. 6 bar
Air consumption 0.2 l/Crimping at 5 bar
Dimensions (diameter x length x height)200 x 135 x 75 mm
Weight approx. 1 000 g

Name plate

Manufacturer
Type of machine
Crimping range
Compressed air connection
Series number/model year

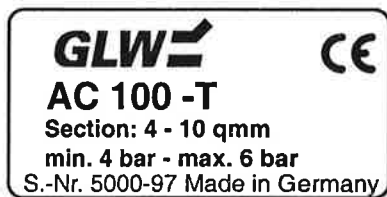

EC symbol

Country of manufacture

Manufacturer: GLW Elektrotechnische Bauteile
Kunststoffverarbeitung GmbH

Address: Steinbeisstraße 2
D-88353 Kisslegg

We hereby declare that the machine described in the following complies with the appropriate fundamental health and safety requirements of the EC Directives regarding machinery with regard to its design and construction as well as the equipment that we have introduced onto the market. This declaration is rendered invalid in the case of amendments to the machine that have not been authorised by our company.

Designation of the
equipment: Pneumatic Crimper

Machine type: AC 100-T



Appropriate
EC Directive: 89/392/EEC

Harmonisation
standard
used: EN292-1, EN292-2 "Safety of machinery"

Place, Date Kisslegg, 30. January 2004

Legally binding signature:



Particulars regarding signatory: Bruno Weiland

GLW GmbH
Steinbeisstraße 2
D-88353 Kisslegg
Tel. 00 49 (0) 7563 9123-0
Fax 00 49 (0) 7563 9123-99

The company GLW retains the copyright to these operating instructions.

It is not permitted to reprint, reproduce or translate, even excerpts, without our consent.

© 1997 GLW GmbH
