

Reversing Switches

ITC now offers a line of ‘Reversing’ switches for three-phase AC motors, manufactured in Germany by Sontheimer GmbH.

As the name suggests, these switches are used to reverse the direction of rotation in small 3-phase electric motors. Note that these devices cannot be used for controlling single-phase AC motors.

These switches are offered in 2 sizes:

- **Size 8**, rated (UL, CSA) 16A, 600VAC
- **Size 32**, rated (UL, CSA) 40A, 600VAC

Three types of mounting can be selected:

- Type E, door mount, 4+1 holes (IP54, IP65 with accessory Z1/D1)
- Type ZM, door mount, single hole $\Phi 22.5\text{mm}$ (IP65)
- Type PM-D1, in plastic enclosure CSA/UL certified (IP 65- Nema 4x)

These switches are built in accordance with all applicable international Standards and are certified by UL and CSA for the North American market, and are economical, compact in size, simple to install, wire and operate.

Features and specifications:

- Standard front plate: Silver with black marking 1-0-2 (plate marked “Reverse-0-Forward” is available upon request)
- **Ingress protection:** see above
- **Rated wire sections:** 14-8 AWG (2.5-10mm²)
- **Temperature range:** -20 to 50°C
- **Approvals:** CSA, cULus, CE-mark, RoHS compliant
- **Accessories available:**
 - Different types of handles, including padlockable models
 - IP65 kit (for type E)
 - Custom front plates
 - Protection housing for switch body (door-mount types)
 - Additional plate identification tag
 - Custom enclosures

Horsepower

Size	Current	3 Phase			
		120 VAC	240 VAC	440 VAC	800 VAC
8	16A	-	-	4.5 HP	-
32	40A	5 HP	10 HP	20 HP	20 HP

Information subject to change without notice



Reversing switches (Order by Part No.)

Part No.	Description	Current CSA/UL	kW (AC3)	Mounting
LBS-W3/8/E	3 position reversing switch door-mount	16A	5.5kW	Door mount
LBS-W3/8/PM-D1	3 position reversing switch in plastic enclosure	16A	5.5kW	Plastic enclosure
LBS-W3/8/ZM	3 position reversing switch centre-mount (22.5mm)	16A	5.5kW	Centre mount
LBS-W3/32/E	3 position reversing switch door-mount	40A	11.0kW	Door mount
LBS-W3/32/PM-D1	3 position reversing switch in plastic enclosure	40A	11.0kW	Plastic enclosure
LBS-W3/32/ZM	3 position reversing switch centre-mount (22.5mm)	40A	11.0kW	Centre mount

Information subject to change without notice

Extra front plates (Order by Part No.)

Part No.	Description	Dimensions	Colour	Marking
LBS-TL0511/X85	Special front plate for Size 8 reversing switch	46x46mm	Silver	"REVERSE-0-FORWARD"
LBS-TL1148/X85	Special front plate for Size 32 reversing switch	62x62mm	Silver	"REVERSE-0-FORWARD"

Information subject to change without notice. Contact ITC for custom and other front plates

Dimensional drawings

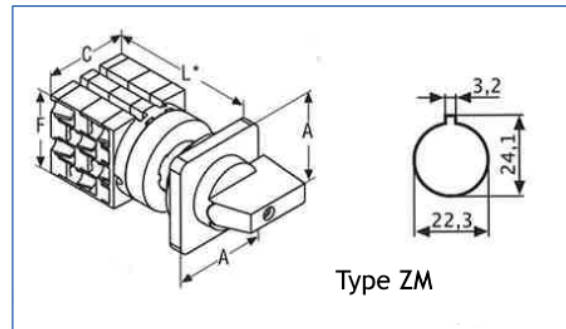
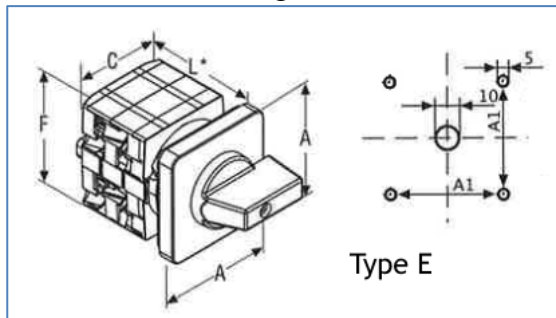

Size	A	A1	C	F	L
8	45	36	40	39	60
32	66	48	54	56	60

Size	A	C	F	L
8	45	40	39	73
32	66	54	56	73

Wiring Diagram

